

Providence

PEC-04

PROGRAMMABLE EFFECTS CONTROLLER

OWNER'S MANUAL

Thank you for choosing a Providence product. In order to take full advantage of the features and performance the product provides, please read this owner's manual thoroughly, and keep it in a safe place for future reference.

◆ Main Features

- * Four programmable effect loops (3 series + 1 separate) plus effect power in a compact unit measuring only 290 mm wide x 70 mm deep.
- * Up to four combinations of the four loops can be programmed and recalled instantly in the PROGRAM mode.
- * The four loops can be directly turned on or off individually in the DIRECT mode.
- * 80 mm footswitch spacing for easy operation.
- * Four DC9V outputs (220 milliamps total) provide convenient power for your effects.
- * DC9V OVERLOAD indicator warns of excessive power drain.
- * Extra-bright LED indicators with high-visibility lenses.

■ Specifications

- Power Supply: AC adaptor (PAP-612ACJ)
- Power Consumption: 5W (with no DC9V power load)
- Dimensions (W x D x H): 290 x 70 x 32 ~ 40 (incl. jacks and switches)
- Weight: 780 grams, approx.
- Supplied Accessories: AC adaptor (PAP-612ACJ), rubber feet x 4

■ Handling Precautions

- Switching the unit on or off while it is connected to an amplifier that is powered on with the volume turned up can damage the amplifier and/or speakers. Make sure the amplifier is turned off, or the PEC-04 is unplugged from the amplifier, when turning the PEC-04 power on or off.
- If the unit malfunctions or behaves erratically, cease operation at once and contact the dealer from which the unit was purchased.

1. Controls and Connectors

■ Top Panel

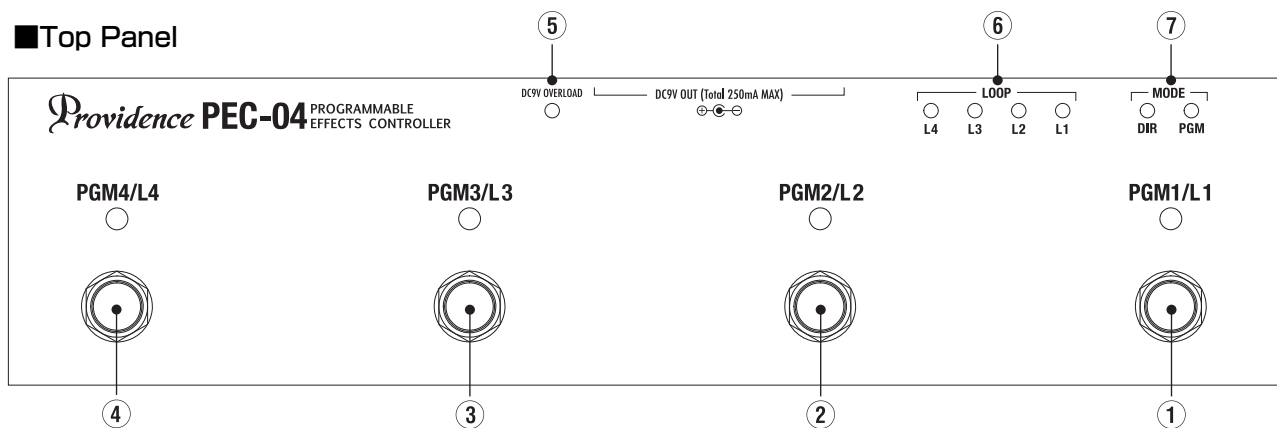

① PGM1/L1 Switch

Recalls the loop combination stored in program 1 when pressed in PGM mode.
Turns LOOP 1 on or off when pressed in DIRECT mode.

② PGM2/L2 Switch

Recalls the loop combination stored in program 2 when pressed in PGM mode.
Turns LOOP 2 on or off when pressed in DIRECT mode.

③ PGM3/L3 Switch

Recalls the loop combination stored in program 3 when pressed in PGM mode.
Turns LOOP 3 on or off when pressed in DIRECT mode.

④ PGM4/L4 Switch

Recalls the loop combination stored in program 4 when pressed in PGM mode.
Turns LOOP 4 on or off when pressed in DIRECT mode.

⑤ DC9V OVERLOAD Indicator

This indicator will light when the current load on the four DC9V outputs exceeds the maximum rated 220 milliamps. When the indicator is lit the power supply circuit is overloaded with the potential for a drop in voltage and a danger of overheating. Do not use the unit while the DC9V OVERLOAD indicator is lit (reduce the total current load to less than 220 milliamps by powering one or more of the connected effects by other means).

⑥ LOOP ON/OFF Indicators

These indicators show the ON/OFF status of the four effect loops. A loop is ON when the corresponding indicator is lit.

⑦ MODE Indicators

These indicators show the current mode of the PEC-04: PGM (PROGRAM), or DIR (DIRECT). The red PGM LED lights when the PROGRAM mode is selected, and the green DIR LED lights when the DIRECT mode is selected.

■ Rear Panel

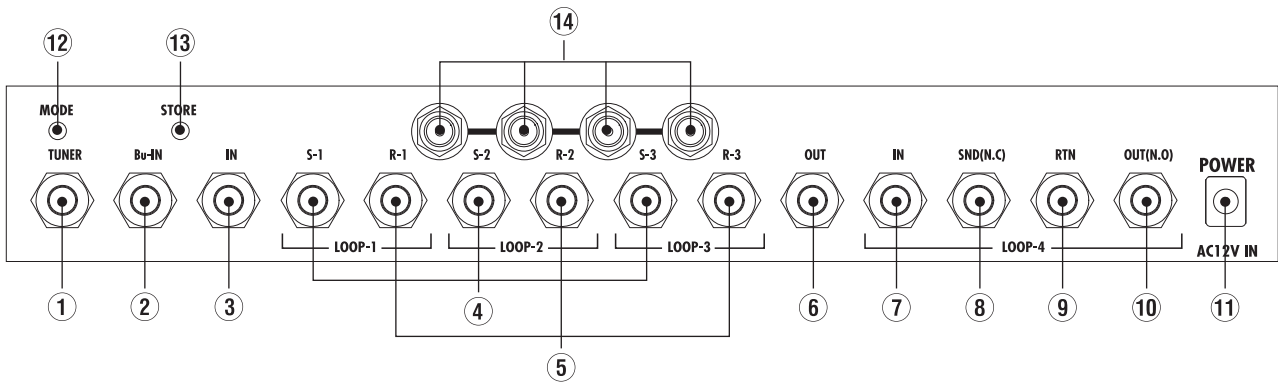

① TUNER

This jack can be connected to a tuner unit, and will continuously feed the signal from either the buffered (Bu-IN) or non-buffered (IN) input to the tuner.

② Bu-IN (Buffered Input)

Signals input via this jack are fed to a buffer circuit prior to being sent to the loops. The buffered input is automatically disabled and isolated from the loops when a plug is inserted into the non-buffered IN jack.

③ IN (Non-buffered Input)

This direct input jack bypasses the buffer circuit, directly feeding the input signal to the loops.

④ S-1 ~ S-3 (Sends 1 ~ 3)

These are the send jacks for loops 1 through 3. These outputs should be connected to the inputs on your effect units.

⑤ R-1 ~ R-3 (Returns 1 ~ 3)

These are the return jacks for loops 1 through 3. The outputs from your effect units should be connected to these inputs.

⑥ OUT

Output jack for the series loops (loops 1 ~ 3). The signal input via the buffered (Bu-IN) or non-buffered (IN) input jack reaches this output jack via the three series loops.

⑦ IN (LOOP 4)

Input to the separate loop (LOOP 4).

⑧ SND (N.C.)

This is the send jack for the separate loop. This output can be connected to the input of an effect unit. When the separate loop is turned off the output from the send jack is muted. This jack

also functions as latching N.C. (Normally Closed) switch and can be connected to an amplifier's channel-switching control jack for remote channel switching: when the loop is OFF the jack is "closed", and when the loop is ON the jack is "open".

⑨ RTN

This is the return jack for the separate loop. The output from your effect unit can be connected to this input.

⑩ OUT (N.O.)

Output from the separate loop (LOOP 4). This jack also functions as a latching N.O. (Normally Open) switch and can be connected to an amplifier's channel-switching control jack for remote channel switching: when the loop is OFF the jack is "open", and when the loop is ON the jack is "closed".

⑪ POWER (AC 12V IN)

The output cable from the supplied AC adaptor should be connected here. Use ONLY the supplied AC adaptor.

⑫ MODE Switch

Pressing this switch alternately selects the PGM (PROGRAM) and DIR (DIRECT) modes.

⑬ STORE Switch

This recessed switch is used to store loop settings when programming loop combinations to be instantly recalled in the PROGRAM mode.

⑭ DC9V OUT Connectors

These four DC power output jacks (center-minus) provide a compact, convenient power source for your 9-volt effect units. Total current supply capacity is 220 milliamps (i.e. the total power consumption of the connected effect units must be less than 220 milliamps).

2. Setup and Operation

The procedure below sets up the PEC-04 for basic 3-series-loop operation.

2-1. Preparation (Making the Connections)

[Caution]: Make sure the amplifier's power is OFF when making initial connections. The amplifier's power should be turned on last.

- 1) Connect the effect units to the PEC-04 loops. The loop send connector (S-1, S-2, or S-3) connects to the effect unit input, and the effect unit output is connected back to the return connector (R-1, R-2, or R-3) of the same loop. For example: S-2 -> Effect -> R-2.
- 2) Connect the DC9V outputs from the PEC-04 to the DC power inputs of your effect units as required (refer to section 4-5 "DC9V Outputs" for details and precautions).
- 3) Connect your instrument to the Bu-IN (buffered input) or IN (direct input) connector.
- 4) Connect the OUT connector to the amplifier's input. If you will be using a tuner you can also connect the TUNER output to your tuner's input.
- 5) Connect the supplied AC adaptor to the PEC-04 and to a convenient AC outlet to power up the unit: the PGM1/L1 indicator will light. Turn on any effect units that need to be powered up as well.
- 6) Turn the amplifier on. Raise the amplifier's volume a little, then raise the volume control on your guitar or bass and play. If you get no sound at this point go back and re-check the connections. When you're getting direct sound, the next step is to check your effect unit connections.
- 7) Press the rear-panel MODE switch to select the DIRECT mode. The green DIR LED will light. In this mode you can use the PGM1/L1 ~ PGM3/L3 switches to individually switch each loop on or off to check operation of the connected effect unit.

Example:

Suppose you have a compressor connected to loop 1, an overdrive pedal connected to loop 2, and a delay effect connected to loop 3. Turn each loop on and off in sequence and make sure that the corresponding effect is functioning properly. If, for example, you get no sound when you get to the overdrive pedal connected to loop 2, check the connections carefully in case one of the plugs is not properly inserted.

2-2. Programming Loop Combinations

- 1) If the PROGRAM is not currently selected (i.e. if the red PGM indicator is not lit) press the rear-panel MODE switch to select the PROGRAM mode (the red PGM indicator will light).
The PROGRAM mode is selected by default when the power is initially applied.
- 2) Each of the unit's footswitches corresponds to one of its four loop programs. Press the footswitch you want to program (PGM1/L1~PGM4/L4) and confirm that the corresponding blue indicator lights.
- 3) After engaging the desired PGM footswitch press the rear-panel MODE switch to switch to the DIRECT mode (the green DIR indicator will light), then use the footswitches to turn the loops ON or OFF as required to create the required combination.
- 4) When the desired loop combination has been set up use the tip of a pen or similar object to press the recessed rear-panel STORE switch. The blue footswitch LED will flash to indicate that the setup has been stored.
- 5) Press the rear-panel MODE switch to return to the PROGRAM mode (the red PGM indicator will light) and confirm that the specified combination has been programmed for the selected footswitch (press the footswitch and watch the LOOP indicators).
- 6) Repeat steps 1 through 5 to program the remaining footswitches as required.

Programming Flowchart

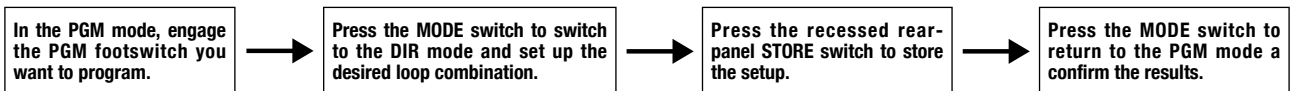

3. Block Diagram

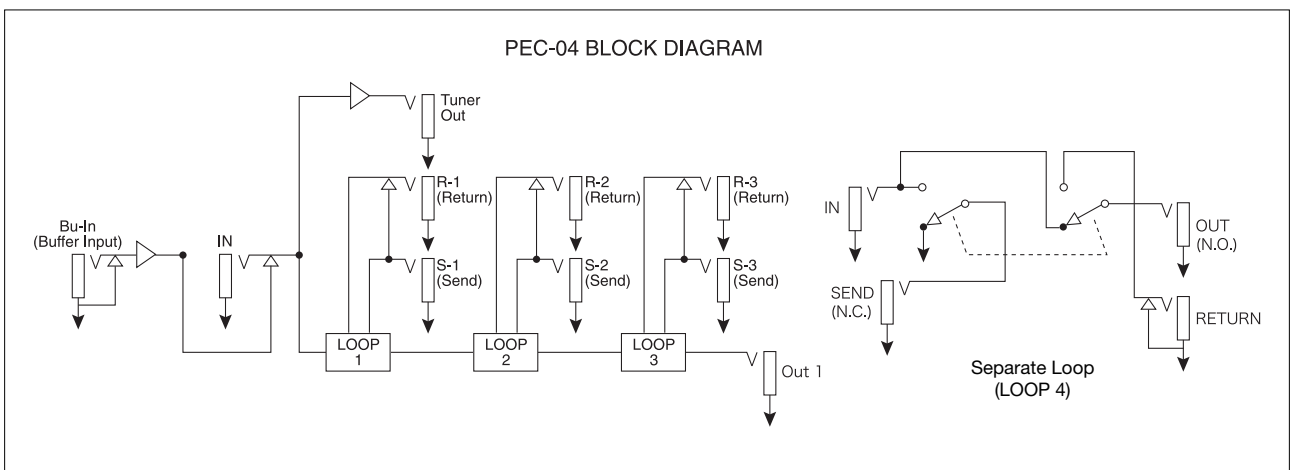

4. Feature Details

4-1. Inputs

● Buffered Input (Bu-IN)

The buffer circuit fed by this input “fortifies” the relatively weak guitar or bass signal without changing the signal level so that it is less susceptible to degradation.

● Direct Input (IN)

The sound of some effects, notably certain types of fuzz and distortion, can change when connected after a buffer circuit. If you will be connecting effects of this type to the PEC-04, connect your instrument to the IN jack to bypass the buffer circuit and connect directly to the effect loops.

4-2. Series Loops

Loops 1 through 3 are connected in series (one after the other). Signal switching is accomplished via precision mechanical relays. When a loop is OFF the corresponding SND output is muted so that no signal is sent to the connected effect unit. This eliminates the possibility of unwanted oscillation due to crosstalk when high-gain effects are used. All loops are S.C.T (Single Contact True-bypass) type circuits, so when a loop is bypassed the signal passes through only a single relay circuit for maximum reliability and sound quality.

4-3. Separate Loops

Loop 4 is totally independent, and uses the same type of precision mechanical relay as loops 1 through 3 for switching. In addition to functioning as an independent loop, the separate loop SND jack can also be used as a latching N.C. (Normally Closed) switch, and the OUT jack can be used as latching N.O. (Normally Open) switch for remote amplifier channel switching. This loop is completely independent, right down to the ground line, so you can use it as a control switch without having to worry about ground loop problems. The separate loop can be used as a mute loop, an A/B switcher, and other utility functions. When the three series loops aren't enough for your system, you can patch the series loop OUT jack to the separate loop IN jack to provide a fourth series loop.

4-4. Tuner Out

The signal received via the buffered input (Bu-IN) or non-buffered input (IN) is always available at this output for connection to an electronic tuner. The tuner output is buffer-isolated from the main signal chain so that a short in the tuner cable or a malfunction in the tuner itself won't affect the main signal.

4-5. DC9V Outputs

The PEC-04 has four precision-regulated DC 9V outputs that can supply a total of 220 milliamps. If the maximum 220 milliamps load is exceeded the red DC9V OVERLOAD indicator will light to warn of a possible voltage drop and overheating. Do not continue to use the unit if the DC9V OVERLOAD indicator lights. Reduce the current load by powering one or more of the connected

CAUTION: Although rare, there are some effect pedals that operate on minus (-) 9V power. The PEC-04 cannot be used to power such pedals, even if a polarity-reversing cable is used. If an effect pedal is labeled to indicate center-plus power, it may be a type that cannot be powered using the PEC-04. If in doubt, please contact Providence for more information.

effects by other means (refer to the documentation provided with your effects for the power consumption of each effect device). In addition to precision regulation, each output features a line noise filter circuit for exceptionally clean DC power, and an overall short protection circuit prevents damage to the power supply circuitry even if one of the outputs is shorted. The DC output connectors are 2.1mm jacks with center-minus polarity.

5. Using the Separate Loop

1) Effect Loops

When the three series loops provided aren't enough for your system, the separate loop can be used as an additional series loop. Connect the input signal (the output from the preceding series loop, for example) to the LOOP 4 IN jack, and connect the LOOP 4 SND (N.C.) jack to the input of the effect unit. The output from the effect unit is then connected back to the LOOP 4 RTN return jack, and the OUT (N.O.) jack is connected to the amplifier.

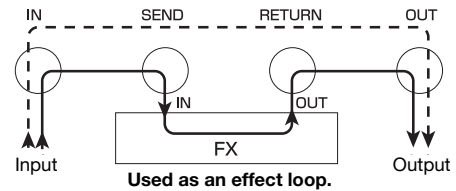

2) Output Selector

This type of connection functions as an output selector, switching the output of the PEC-04 to one of two amplifiers or other devices. When the separate loop is ON the signal is output via the SND (N.C.) jack while the OUT (N.O.) output is muted so that crosstalk and noise are eliminated. When the loop is OFF the signal is output via the OUT (N.O.) jack and the SND (N.C.) output is muted. Connect the input signal to the IN jack, the SND (N.C.) jack to one amplifier or other device, and the OUT (N.O.) jack to the second amplifier or other device. Leave the RTN jack unconnected.

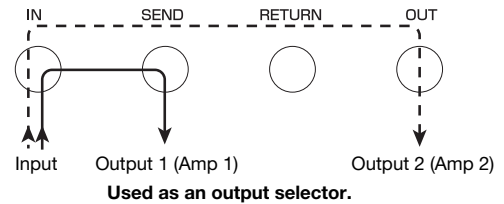

3) Input Selector

In this configuration the separate loop functions as an input or source selector, selecting one of two input signals to be fed to a single output. When the loop is ON the signal connected to the RTN jack is routed to the OUT (N.O.) jack. When the loop is OFF the signal connected to the separate loop IN jack is routed to the OUT (N.O.) jack. Leave the SND (N.C.) jack unconnected.

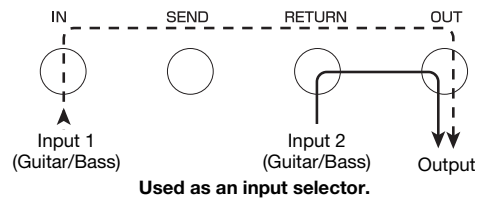

4) Output (Send) ON/OFF Switch

The separate loop is also an ideal way to simply turn output on or off. When the loop is ON the input signal is output via the SND (N.C.) jack, and when the loop is OFF the send jack output is muted. This is a handy way to turn a D.I. send on or off.

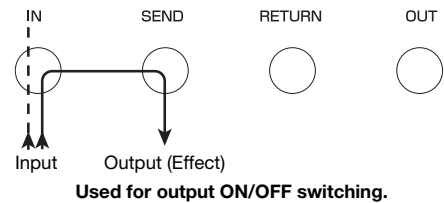

6. Application Examples

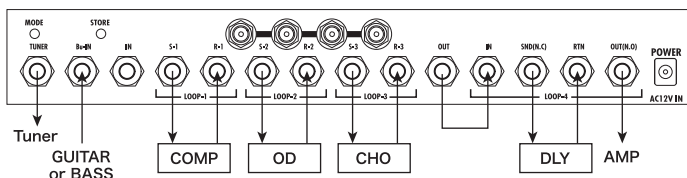

1. Four Effect Loops

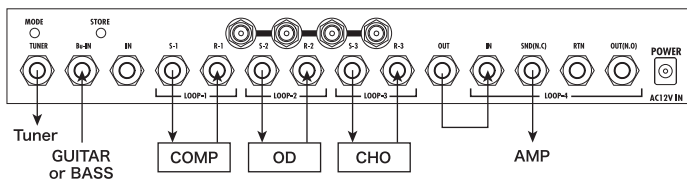

2. Three Effect Loops Plus Output Muting

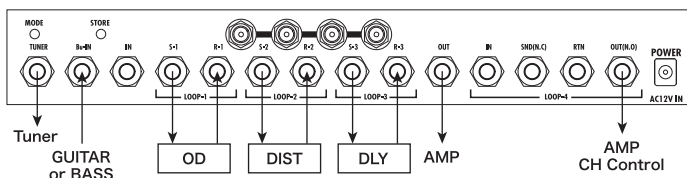
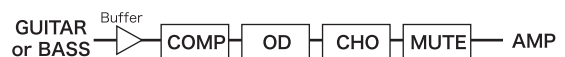

3. Three Effect Loops Plus Amp Channel Switching

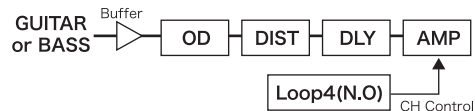

PACIFIX, LTD.
SOUND PRODUCT & SYSTEM DESIGN

3-21-7, Tsurumi-Chuo Tsurumi-ku, Yokohama-shi, Kanagawa 230-0051 JAPAN
TEL.0081-45-510-4060 FAX.0081-45-510-4061
E-mail. overseas1@pacifix-ltd.com URL. www.providence.jp